

ATTREZZI ECOLOGICI

ENVIRONMENTAL EQUIPMENT
OUTILS ECOLOGIQUES
ENTSORGUNGSGERÄTE

Made in Italy 

PRESSA ELETTRIDRAULICA SCHIACCIA FILTRI

ELECTROHYDRAULIC FILTER CRUSHER
PRESSE ELECTROHYDRAULIQUE ECRASE FILTRES
ELEKTROHYDRAULISCHE FILTER-PRESSE



ART. 389/A

ART. 389/A

Pressa elettroidraulica a due velocità di lavoro. Compatta i filtri olio di tutti gli autoveicoli ed ottiene un doppio risultato: il recupero totale dell'olio residuo e la massima riduzione dell'ingombro dei filtri stessi. L'olio ed i filtri schiacciati vengono raccolti automaticamente a caduta libera in due distinti contenitori. Il contenitore per i filtri è munito di un cestello che, oltre alla raccolta degli stessi, consente lo sgocciolamento dell'eventuale minimo residuo di olio. I benefici ecologici, il ritorno economico derivato dal recupero e dalla facilitazione di riciclaggio dell'olio e dei filtri, la sua realizzazione in armadio carrellato (quattro ruote di cui due orientabili) e gli accorgimenti antinfortunistici testimoniano l'indiscussa utilità in qualsiasi officina di questa schiaccia filtri. Relé di sicurezza chiusura vano di lavoro.

Two working speed electrohydraulic press. It compresses the oil filters of every vehicle and it obtains the total salvage of the residual oil and of the highest reduction of encumbrance of the filters themselves. The oil and compressed filters are automatically collected in free-fall in two separated containers. The filter container is equipped with a basket that, besides collecting the filters, allows the dripping of the possible residual oil. The undisputed usefulness of this filter crusher in any car workshop is proved by the environmental benefits, the economic return derived from the salvage and the oil and filter recycling facilities, the fact that it is structured as a trolley cupboard (with four wheels of which two revolving) and the accident-prevention devices. Safety relay controlled closure of the working room.

Presse électrohydraulique, à deux vitesses de travail. Elle comprime les filtres d'huile de toutes les voitures en obtenant un double résultat la récupération des résidus d'huile et la réduction maximale des filtres eux-mêmes. L'huile et les filtres écrasés sont récupérés automatiquement dans deux réceptacles distincts. Le réceptacle à filtre est équipé d'un panier percé, pour recueillir un éventuel résidu d'huile. Les bénéfices écologiques, le retour économique qui passe par la récupération et la facilité de recyclage des filtres et de l'huile, sa présentation en armoire amovible (quatre roues dont 2 pivotantes) et les normes de travail, témoignent de l'indiscutable utilité de l'écrase filtres dans tous les garages.

Elektrohydraulische Presse mit 2 Arbeitsgeschwindigkeiten. Ölfilter jeden Fahrzeugtyps lassen sich hiermit zusammenpressen, wobei das anfallende Altöl gesammelt wird. Öl und Filter werden automatisch in zwei Behältern gesammelt; durch einen Korbeinsatz im Filtersammelbehälter kann das im Filter verbliebene Restöl abtropfen. Die unbestrittenen Vorteile der Filter-Pressen liegen in ihrer Umweltfreundlichkeit, d.h. der getrennten Wiederverwertung von Altöl und der anfallenden Reststoffe, der Konzeption als Schrankwagen (4 Räder - 2 davon drehbar) sowie entsprechenden Vorrichtungen zur Unfallverhütung. Das Schließen der Preßkammer wird durch ein Sicherheitsrelais gesteuert.

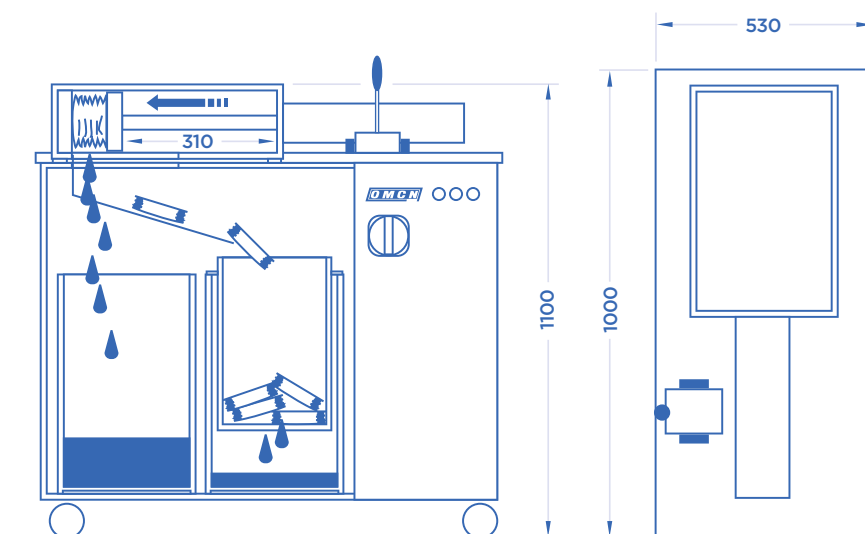

ART.	TON		Dimensioni camera Working room dimensions Dimensions chambre Maße der Preßkammer	
389/A	40	1,5 kw	175 x 260 x 320 mm	250

 Potenza motore • Motor power • Puissance moteur • Motorleistung

**PRESE IDRAULICHE
SCHIACCIA BARATTOLI**

CAN CRUSHING HYDRAULIC PRESSES
PRESSES HYDRAULIQUES A COMPRIMER LES POTS ET BIDON DE PEINTURE
HYDRAULIK-PRESSE FÜR DAS ZUSAMMENPRESSEN VON BLECHDOSEN

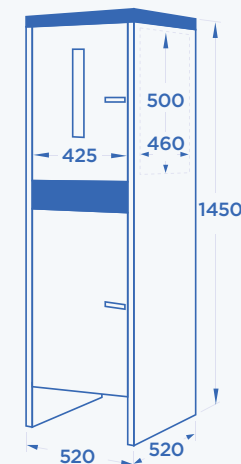

ART. 390/A



ART. 390/B

ART. 390/A

Pressa completa di pompa elettroidraulica.

Press complete with electrohydraulic pump.

Presse munie de pompe électrohydraulique.

Presse, komplett ausgestattet mit elektrohydraulischer Pumpe.

ART. 390/B

Pressa completa di pompa idropneumatica.

Press complete with hydropneumatic pump.

Presse munie de pompe hydropneumatique.

Presse, komplett ausgestattet mit pneumatisch-hydraulischer Pumpe.

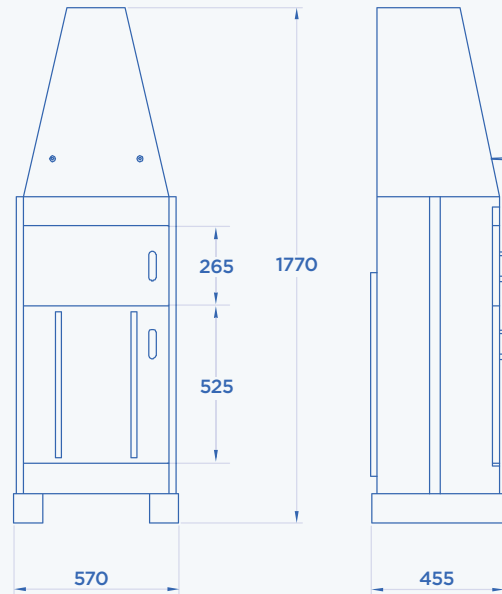

ART.	KG	Corsa pistone Ram stroke Course du piston Kolbenhub					
			mm	mm	mm	mm	KG
396	700	500 mm	10 bar	500	780	400	150

Indicata per carta e cartone, a funzionamento pneumatico è dotata di doppio bloccaggio di sicurezza e di pianale inferiore parzialmente estraibile per una più facile evacuazione della palla formata.

Indicated for paper and cardboard, pneumatic working it is provided with twin safety locking and lower partially extractable planal for an easier evacuation of the formed bale.

Indiquée pour le traitement des papier et carton. Fonctionnement pneumatique. Pourvu d'un double blocage de sécurité et d'un fond extractible pour faciliter l'évacuation de la balle formée.

Pneumatisch arbeitende Presse für Papier und Pappe, ausgestattet mit doppeltem Sicherheitsverschluß und einem teilweise ausziehbaren Tisch, mit dessen Hilfe, sich der gepreßte Ballen einfach entnehmen läßt.

*Dimensioni vano • Room dimensions • Dimensions de la chambre • Ballenmaße

Pressione di utilizzo • Feeding pressure • Pression d'alimentation • Benötigter Luftdruck



VASCHE ECOLOGICHE

TANKS OF DUMP AGAINST THE ACCIDENTAL LOSSES
BACS DE RECOLTE CONTRE LES FUITES ACCIDENTELLES
ÖLAUFFANGBEHÄLTER

Da posizionare su superfici piane, protette dalla pioggia. In presenza di immagazzinaggio di sostanze diverse, le stesse dovranno essere tra loro compatibili.

To put on plane surfaces, protected by the rain. If there is a storing of different substances, these ones shall be each others compatible.

A positionner sur des surfaces planes à l'écart des intempéries. Ne pas stocker ensemble des produits incompatibles.

Dieser Behälter dient zum Auffangen von Öl aus undichten oder überlaufenden Ölfässern.



ART. 5000



ART. 5001/M





ART. 5002

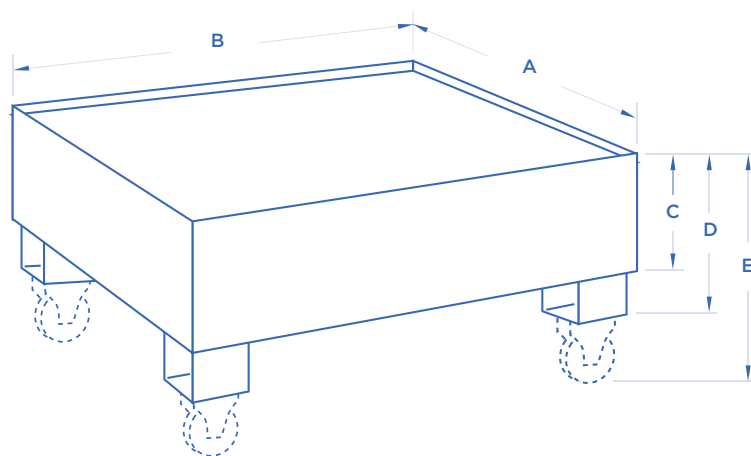

ART.		A mm	B mm	C mm	D mm	E mm	KG
5000	210	850	1000	250	355		54
5000/M	210	850	1000	250	355	525	60
5001	285	850	1350	250	355		80
5001/M	285	850	1350	250	355	525	86
5002	450	1000	1800	250	355		113
5002/M	450	1000	1800	250	355	525	120

 Capacità • Capacity • Capacité • Belastbarkeit

 Versione mobile • Mobile version • Version mobile • Fahrbare Ausführung